

The Boom Gate System

Ezi Security manufacture its products where we are able to guarantee optimum quality control
 Ezi Security specialises in the manufacturing, sales, installations and servicing of physical barrier systems to our exacting standards



The Ezi Boom gate system is specifically designed as a true industrial quality product. Whether it's to regulate traffic, warn of danger or to implement traffic calming, the Ezi boom gate provides reliable and trouble free performance.

With a quality torque drive motor/gearbox and state of the art electronics the Ezi boom gates offers a true 100% duty cycle product.

Our logic control, through the use of a true PLC, offers high performance and reliability through the use of Ezi's proven software programming expertise. This PLC system also allows for special and auxiliary features to be added without major parts redundancy. For example, traffic light controls, flashing and audible warnings and indeed full compatibility with all access control systems.

All Ezi boom gates are of robust design and constructed in stainless steel and powder coat painted. This is done to overcome

extreme corrosive environments and give longevity to the working life of the product.

Of course access to our cabinets is via a secure and lockable cabinet door that provides serviceability and access to electronic controls and the torque drive mechanism.

Boom arms are constructed from round aluminium and provide strength with light weight characteristics. For maximum visibility the arms are powder coated white with UV resistant red reflective tape applied to both traffic approach faces for high visibility at night.

The Ezi boom gate ranges offers boom arm lengths of up to 6-metres with the gates designed to operate all day, everyday, with barrier raise times from 3 to 5.5 seconds.

Raise times will vary and are dependant upon

the boom arm length and weight.

Various optional equipment is also available upon request. Examples are outlined below:

- Restricted height arm kits "Articulate" (up to 4.5 metres).
- Traffic control lights
- illuminated full signs
- Magnetic lock and end posts
- Free entry and exit loops systems
- Validation loop systems
- Equipment pedestals and protective bollards
- High visibility boom skirts
- Coin or token mechanisms.
- Token and coin housings
- Token & coin collection chutes and safes.

If you are looking for a durable and ultra reliable boom gate system, contact the experts at Ezi Systems.



Technical Data for Standard Boom Gate

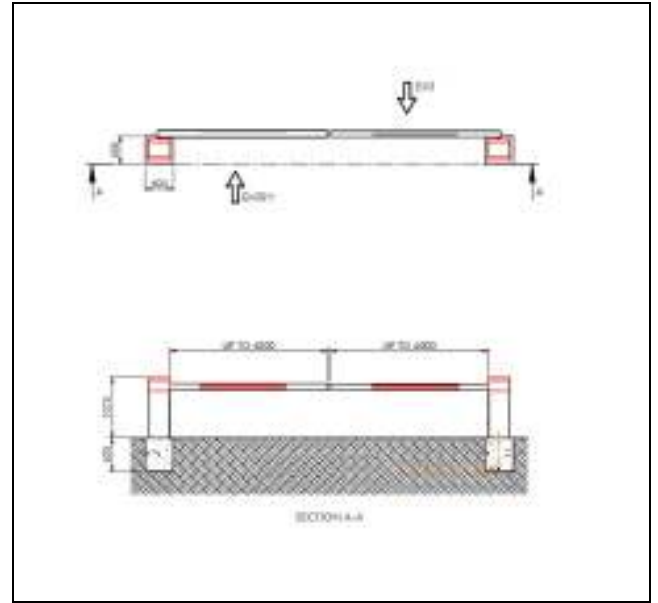
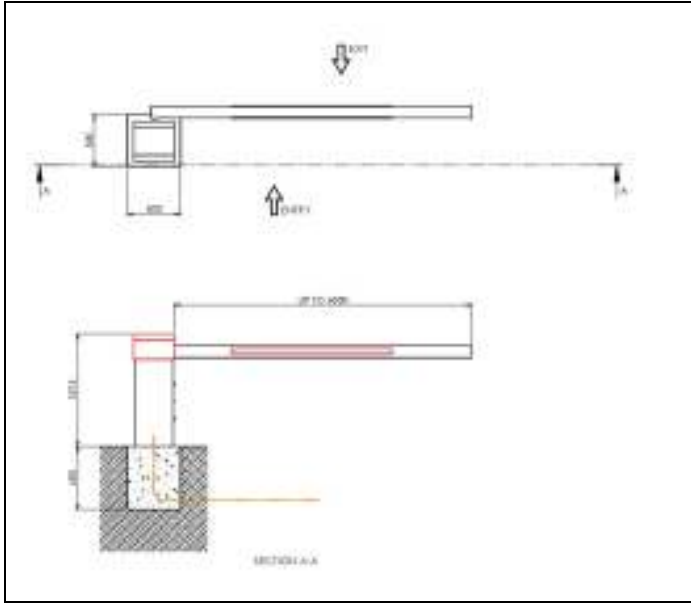

Standard Boom Gate Specifications

Barrier Models	Type 1: 3.0 – 4.5 metre boom capacity Type 2: 4.5 – 6.0 metre boom capacity
Boom housing width	360mm x 360mm
Boom housing height	1075mm
Ground to centre of boom	885mm
Housing material	Stainless steel, type 304
Housing finish	Powder coat painted
Housing colour	White
Top hood colour	Red
Boom material	Round aluminum
Boom diameter	76.2mm OD
Boom control	True PLC
Boom motor- type 1	TM90 torque motor gearbox
Boom motor- type 2	TM120 torque motor gearbox
Max boom length	6000mm
Boom handing	Left or right hand
Vehicle safety	Safety loop and detector
Pedestrian safety	Additional photo cell and post
Motor power	60 watt
Power requirement	240v, 15amp, 50hz single phase
Access control	Dependant on system
Foundation	600mm deep x 500mm wide
Barrier raise time	Type 1: 3 seconds Type 2: 5.5 seconds
Duty cycle	True 100% cycling as per stand

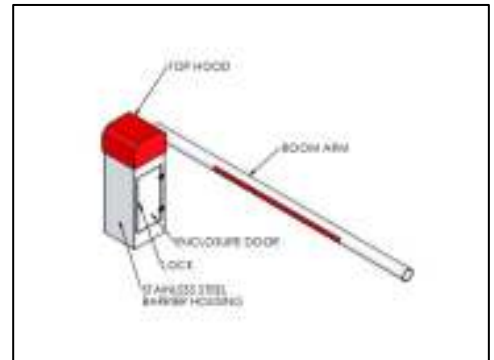

EZI SECURITY SYSTEMS has established an enviable reputation in the Australian security industry since its inception in 1993. This Australian owned company is renowned for its quality craftsmanship and outstanding customer service support.
ABN: 60 124 510 783 **MASTER LICENCE:** 408433168 **ASIAL:** 025567